

IRBB

Inert gas damper

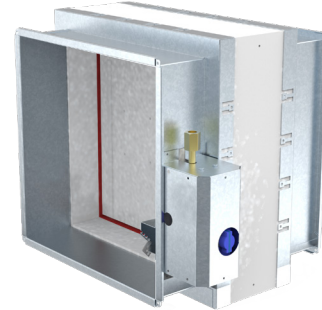

INSTALLATION IN STRUCTURAL ELEMENT

FIRE RESISTANCE CLASS EI 60/EI 120

1. Recess CxD is 130 mm larger than damper opening AxB.
2. Building structure made of sheet material (e.g. plaster board) is reinforced with a stud around the hole.
3. Damper is centred in the recess and positioned with the damper blade in the middle of the building structure. The damper is mounted with the damper axis in horizontal position and the drive unit to the right side*.
4. If necessary, the weight of the damper can be supported against a fixed structure. The load bearing capacity of the mounting must meet the fire resistance class requirements of the structural element being penetrated.
5. Mounting plate is installed against the wall to cover the recess.
6. Space between the structural element and the damper is sealed with material approved for the purpose.
7. Damper opening is fitted with a grille.

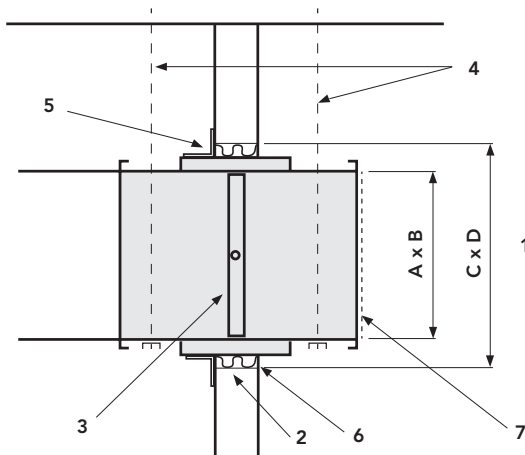

INSTALLATION ON STRUCTURAL ELEMENT

FIRE RESISTANCE CLASS EI 60/EI 120

1. Recess CxD is 60 mm larger than damper opening AxB.
2. Building structure made of sheet material (e.g. plaster board) is reinforced with a stud around the hole.
3. For installation in holes deeper than 135 mm, the damper is fitted with a custom extension adapter to pass through the length of the hole.
4. Damper is centred in the recess and fastened to the building structure using installation angles. The damper is mounted with the damper axis in horizontal position and the drive unit to the right side*.
5. If necessary, the weight of the damper can be supported against a fixed structure. The load bearing capacity of the mounting must meet the fire resistance class requirements of the structural element being penetrated.
6. Space between the structural element and the damper is sealed with material approved for the purpose.
7. Damper opening is fitted with a grille.

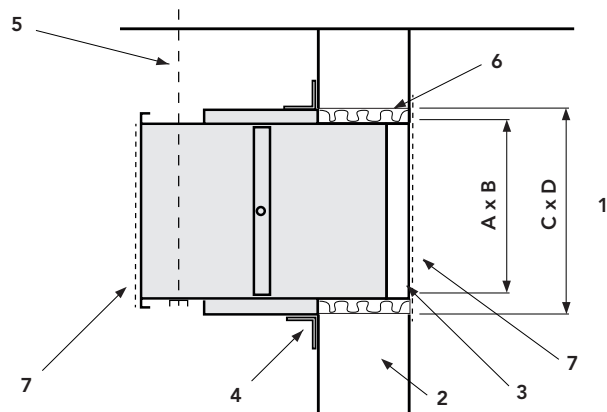

IRBB

Inert gas damper

INSTALLATION AWAY FROM STRUCTURAL ELEMENT FIRE RESISTANCE CLASS EI 60/EI 120

1. Recess CxD is adjusted to match the connecting duct dimension.
2. If necessary, the damper can be supported against a fixed structure. The load bearing capacity of the mounting must meet the fire resistance class requirements of the structural element being penetrated. The damper is mounted with the damper axis in horizontal position and the drive unit to the right side*.
3. Ventilation duct between the structural element and the damper is insulated to the same fire resistance class as the structural element being penetrated. There must be no openings on the ventilation duct between the damper and the structural element.
4. Space between the ventilation duct and the structural element is sealed with material approved for the purpose.
5. Damper opening is fitted with a grille.

HAGAB ensures that production of its IRBB Inert Gas Damper is carried out in accordance with Manufacturing Control/ Type Approval SC0001-13 and its supporting documents.

The damper is mounted with the damper shaft in the horizontal position, upright or upside down.

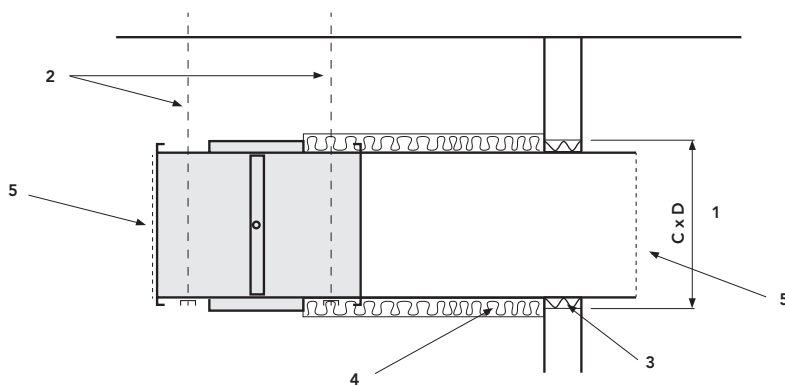

* It is also possible to get the drive unit mounted on the left side.